

**TV145 Tractor
Repair Manual 87038775
Complete Table of Contents**



Description	Book Number	Section Number	Chapter Number
General Information	87038777	00	
Engine - 7.5L	87038777	10	1
Engine - Fuel System	87038777	10	2
Engine - Air Induction System	87049448	10	3
Engine - Exhaust System	87049448	10	4
Engine - Cooling System	87049448	10	5
Engine - Engine Removal	87049448	10	6
Transmissions - General Information, Specifications and Splitter Box Operation	87049449	21	1
Transmissions - Drivelines	87049449	21	2
Transmissions - Auxiliary Pump Drive	87049449	21	3
Transmissions - Splitter Box Removal, Disassembly and Assembly	87049449	21	4
Transmissions - Auxiliary Hydraulic Pump	87049449	21	5
Transmissions - Hydrostatic Drive	87049449	21	6
Transmissions - Hydrostatic Motor, Pump and Control Cables	87049449	21	7
Engine-End Axle	87049449	25	1
Cab-End Axle	87049449	27	1
PTO - Cab End	87049450	31	1
PTO - Engine End	87049450	31	2
Brakes	87038779	33	1
Hydraulic Systems - Hydraulics and Steering	87038779	35	1
Hydraulic Systems - Cab End Hitch	87049451	35	2
Hydraulic Systems - Engine End Hitch	87049451	35	3
Wheels and Tires	87049451	37	1

Description	Book Number	Section Number	Chapter Number
Ballasting	87049451	37	2
Frames	87049451	39	1
Climate Control	87038780	50	1
Electrical System	87038780	55	1
Accessories	87038781	88	1
Cab - General Information	87038781	90	1
Cab - Removal and Installation	87038781	90	2
Cab - Exterior	87038781	90	3
Cab - Interior	87038781	90	4
Cab - Control Consoles	87038781	90	5



**TV145 Tractor
Repair Manual
Table of Contents**



Description	Section Number	Chapter Number
General Information	00	
Engine - 7.5L	10	1
Engine - Fuel System	10	2

SECTION 00 - GENERAL INFORMATION

CONTENTS

Section	Description	Page
00 000	Precautionary Statements	3
	Safety Precautions	3
	General Considerations	5
	Tractor Identification	12
	Engine Identification	15
	Service Techniques	17
	Minimum Hardware Tightening Torques	18
	Standard Torque Data	20
	Recommended Lubricants and Coolants	22
	Recommended Sealants	24

FOREWORD

Appropriate service methods and correct repair procedures are essential for the safe, reliable operation of all equipment, as well as the personal safety of the individual performing the repair.

This Repair Manual provides troubleshooting, overhaul, and pressure-testing instructions using recommended procedures and equipment. Following these instructions will ensure the safe, efficient, and timely completion of the service or repair.

There are numerous variations in procedures, techniques, tools, and parts for servicing machines, as well as in the skill of the individual doing the work. This manual cannot possibly anticipate all such variations and provide advice or cautions as to each. Accordingly, anyone who departs from the instructions provided in this manual must first establish that their personal safety, the safety of others, and the integrity of the machine will not be compromised by the choice of methods, tools or parts.

The manual is divided into sections which are subdivided into chapters: Each chapter contains information on general operating principles, detailed inspection, overhaul and, where applicable, specific troubleshooting, special tools, and specifications.

Any reference in this manual to right, left, rear, front, top, or bottom is as viewed from the operator's seat, looking toward the engine.

All data and illustrations in this manual are subject to variations in build specification. This information was correct at the time of issue, but New Holland policy is one of continuous improvement, and, the right to change specifications, equipment, or design at any time, without notice, is reserved.

ABOUT IMPROVEMENTS

New Holland is continually striving to improve its products. We must, therefore, reserve the right to make improvements or changes when it becomes practical and possible to do so, without incurring any obligation to make changes or additions to the equipment sold previously.

ALL SPECIFICATIONS ARE SUBJECT TO CHANGE WITHOUT NOTICE.

PART AND ACCESSORIES

Genuine NEW HOLLAND parts and accessories have been specifically designed for NEW HOLLAND MACHINES.

We would like to point out that "NON GENUINE parts and accessories have not been examined and released by NEW HOLLAND. The installation and or use of such products could have a negative effect upon the design characteristics of your machine and thereby affect its safety. NEW HOLLAND is not liable for any damage caused by the use of "NON GENUINE" NEW HOLLAND parts and accessories.

PRECAUTIONARY STATEMENTS

PERSONAL SAFETY

Throughout this manual and on machine decals, you will find precautionary statements (“DANGER”, “WARNING”, and “CAUTION”) followed by specific instructions. These precautions are intended for the personal safety of you and those working with you. Please take the time to read them.

—————  **DANGER**  —————

This word “DANGER” indicates an immediate hazardous situation that, if not avoided, will result in death or serious injury. The color associated with Danger is RED.

—————  **WARNING**  —————

This word “WARNING” indicates a potentially hazardous situation that, if not avoided, could result in death or serious injury. The color associated with Warning is ORANGE.

—————  **CAUTION**  —————

This word “CAUTION” indicates a potentially hazardous situation that, if not avoided, may result in minor or moderate injury. It may also be used to alert against unsafe practices. The color associated with Caution is YELLOW.

FAILURE TO FOLLOW THE “DANGER”, “WARNING”, AND “CAUTION” INSTRUCTIONS MAY RESULT IN SERIOUS BODILY INJURY OR DEATH.

MACHINE SAFETY

The additional precautionary statement (“IMPORTANT”) is followed by specific instructions. This statement is intended for machine safety.

IMPORTANT: *The word “IMPORTANT” is used to inform the reader of something he needs to know to prevent minor machine damage if a certain procedure is not followed.*

INFORMATION

NOTE: *Instructions used to identify and present supplementary information.*

SAFETY PRECAUTIONS

Practically all service work involves the need to drive the tractor. The operator’s manual, supplied with each tractor, contains detailed safety precautions relating to driving, operating, and servicing that tractor. These precautions are as applicable to the service technician as they are to the operator and should be read, understood and practiced by all personnel.

Prior to undertaking any maintenance, repair, overhaul, dismantling or reassembly operations, whether within a workshop facility or in the field, consideration should be given to factors that may have an effect upon safety, not only upon the mechanic carrying out the work, but also upon bystanders.

PERSONAL CONSIDERATIONS

The wrong clothes or carelessness in dress can cause accidents. Check to see that you are suitable clothed.

Some jobs require special protective equipment.

Skin Protection

Used motor oil may cause skin cancer. Follow work practices that minimize the amount of skin exposed and length of time used oil stays on your skin.

Eye Protection

The smallest eye injury may cause loss of vision. Injury can be avoided by wearing eye protection when engaged in chiselling, grinding, discing, welding, and painting.

Breathing Protection

Fumes, dust, and paint spray are unpleasant and harmful. These can be avoided by wearing respiratory protection.

Hearing Protection

Loud noise may damage your hearing, and the greater the exposure the worse the damage. If the noise is excessive, wear ear protection.

Lifting Protection

Avoid injury by correctly handling components. Make sure you are capable of lifting the object. If in doubt get help.

Hand Protection

It is advisable to use a protective cream before work to prevent irritation and skin contamination. After work clean your hands with soap and water. Solvents such as mineral spirit and kerosene may harm the skin.

Foot Protection

Substantial or protective foot wear with reinforced toe caps will protect your feet from falling objects. Additionally, oil-resistant soles will help to avoid slipping.

Special Clothing

For certain work it may be necessary to wear flame or acid-resistant clothing.

EQUIPMENT CONSIDERATIONS

Machine Guards

Before using any machine, check to ensure that the machine guards are in position and serviceable. These guards not only prevent parts of the body or clothing coming in contact with the moving parts of the machine, but also ward off objects that might fly off the machine and cause injury.

Lifting Devices

Always ensure that lifting equipment, such as chains, slings, lifting brackets, hooks and eyes, are thoroughly checked before use. If in doubt, select stronger equipment than is necessary.

Never stand under a suspended load or raised implement.

Compressed Air

The pressure from a compressed-air line often exceeds 100 PSI (690 kPa). It is perfectly safe if used correctly. Any misuse may cause injury.

Never use compressed air to blow dust, filing, and dirt away from your work area unless the correct type of nozzle is fitted.

Compressed air is not a cleaning agent; it will only move dust from one place to another. Look around before using an air hose as bystanders may get grit into their eyes, ears, or skin.

Hand Tools

Many cuts, abrasions and injuries are caused by defective tools. Never use the wrong tool for the job, as this generally leads either to some injury or to a poor job.

When removing or replacing hardened pins, use a copper or brass drift rather than a hammer.

For dismantling, overhaul, and assembly of major and sub-components, always use the Special Service Tools recommended. These will reduce the work effort, labor time, and the repair cost.

Electricity

Electricity has become so familiar in day to day usage, that its potentially dangerous properties are often overlooked. Misuse of electrical equipment can endanger life.

Before using any electrical equipment particularly portable appliances - make a visual check to make sure that the wiring is not worn or frayed and that the plugs and sockets are intact. Make sure you know where the nearest isolating switch for your equipment is located.

GENERAL CONSIDERATIONS

Solvents

Use cleaning fluids and solvents that are known to be safe. Certain types of fluids can cause damage to components, such as seals, and can cause skin irritation. Solvents should be checked that they are suitable not only for the cleaning of components and individual parts, but also that they do not affect the personal safety of the user.

Housekeeping

Many injuries result from tripping over or slipping on objects or material left lying around by a careless worker. Prevent these accidents from occurring. If you notice a hazard, don't ignore it remove it.

A clean, hazard-free place of work improves the surroundings and daily environment for everybody.

Fire

Fire has no respect for persons or property. The destruction that a fire can cause is not always fully realized. Everyone must be constantly on guard.

Extinguish matches, cigars, and cigarettes before throwing them away.

Work cleanly, disposing of waste material into proper containers.

Locate the fire extinguishers and find out how to operate them.

Do not panic - warn those near and raise the alarm.

Do not allow or use an open flame near the tractor fuel tank, battery, or component parts.

First Aid

In the type of work that mechanics are engaged in, dirt, grease, and fine dusts settle upon the skin and clothing. If a cut, abrasion or burn is disregarded it may become infected within a short time. Seek medical aid immediately.

Cleanliness

Cleanliness of the tractor hydraulic system is essential for optimum performance. When carrying out service and repairs, plug all hose ends and component connections to prevent dirt entry.

Clean the exterior of all components before carrying out any form of repair. Dirt and abrasive dust can reduce the efficiency and working life of a component and lead to costly replacement. Use of a high-pressure washer or steam cleaner is recommended.

OPERATIONAL CONSIDERATIONS

Stop the engine, if at all possible, before performing any service.

Place a warning sign on tractors which, due to service or overhaul, would be dangerous to start. Disconnect the battery leads if leaving such a unit unattended.

Do not attempt to start the engine while standing beside the tractor or attempt to bypass the safety start switch.

Avoid prolonged running of the engine in a closed building or in an area with inadequate ventilation as exhaust fumes are highly toxic.

Always turn the radiator cap to the first stop to allow pressure in the system to dissipate when the coolant is hot.

Never work beneath a tractor which is on soft ground. Always take the unit to an area which has a hard working surface, preferably concrete.

If it is found necessary to raise the tractor for ease of servicing or repair, make sure that safe and stable supports are installed beneath axle housings, casings, etc., before starting work.

Certain repair or overhaul procedures may necessitate separating the tractor, either at the engine/transmission or transmission/rear axle location. These operations are simplified by the use of the Tractor Splitting Stands. Should this equipment not be available, every consideration must be given to stability, balance and weight of the components, especially if a cab is installed.

Use footsteps or working platforms when servicing those areas of a tractor that are not within easy reach.

Before loosening any hoses or tubes connecting implements to remote control valves, etc., switch off the engine, remove all pressure in the lines by operating levers several times. This will remove the danger of personal injury by oil pressure.

Prior to pressure testing, make sure all hoses and connectors of the tractor and the test equipment are in good condition and tightly sealed. Pressure readings must be taken with the gauges specified. The correct procedure should be rigidly observed to prevent damage to the system or the equipment, and to eliminate the possibility of personal injury.



Escaping hydraulic/diesel fluid under pressure can penetrate the skin causing serious injury.



Do not use your hand to check for leaks. Use a piece of cardboard or paper to search for leaks. Stop the engine and relieve pressure before connecting or disconnecting lines.

Tighten all connections before starting the engine or pressurizing lines.

If any fluid is injected into the skin, obtain medical attention immediately or gangrene may result.

Use “position control” when equipment or implements are required to be attached to the hydraulic linkage either for testing purposes or for transportation.

Always lower equipment to the ground when leaving the tractor.

If high lift attachments are installed on a tractor, beware of overhead power, electric or telephone cables when travelling. Drop the attachment near to ground level to increase stability and minimize risks.

Do not park or attempt to service a tractor on an incline. If unavoidable, take extra care and block all wheels.

Observe recommended precautions as indicated in this Service Manual when dismantling the air conditioning system as escaping refrigerant can cause frostbite.

Prior to removing wheels and tires from a tractor, check to determine whether additional ballast (liquid or weights) has been added. Seek assistance and use suitable equipment to support the weight of the wheel assembly.

When inflating tires, beware of over inflation - constantly check the pressure. Over inflation can cause tires to burst and result in personal injury.

SERVICING A TRACTOR WITH A LOADER INSTALLED

If the tractor is equipped with a loader, lower the loader and rest the bucket on the ground.

If servicing the tractor and the loader must be raised, empty the bucket and curl the bucket to fully retract the bucket cylinders. Raise the loader and install the loader supports over the cylinder rods and lower the loader on the supports.

HEALTH AND SAFETY PRECAUTIONS

Many of the procedures associated with vehicle maintenance and repair involve physical hazards or other risks to health. This section lists, alphabetically, some of these hazardous operations, materials and equipment associated with them. The precautions necessary to avoid these hazards are identified.

The list is not inclusive; all operations, procedures, and handling of materials should be carried out with health and safety in mind.

ACIDS AND ALKALIS (SEE BATTERY ACIDS, I.E., CAUSTIC SODA, SULPHURIC ACID)

Used in batteries and cleaning materials.

Irritating and corrosive to the skin, eyes, nose and throat. Causes burns.

Avoid splashes to the skin, eyes, and clothing. Wear suitable protective gloves and goggles. Can destroy ordinary protective clothing. Do not breathe mists.

Ensure access to water and soap is readily available for splashing accidents.

ADHESIVES AND SEALERS (SEE FIRE)



Highly flammable, combustible.

Generally should be stored in “NO SMOKING” areas; cleanliness and tidiness while in use should be observed, i. e., from applications where possible, disposable paper should be dispensed to cover benches. Containers, including secondary containers, should be labelled.

Solvent-Based Adhesives/Sealers (See Solvents)

Follow manufacturer’s Instructions

Water-Based Adhesives/Sealers

Those based on polymer emulsions and rubber lattices may contain small amounts of volatile toxic and harmful chemicals.

Skin and eye contact should be avoided, and adequate ventilation provided during use.

Follow manufacturer’s Instructions

Resin-Based Adhesive/Sealers (i.e., Epoxide and Formaldehyde Resin Based)

Mixing should only be carried out in well-ventilated areas as harmful or toxic volatile chemicals may be released.

Skin contact with uncured resins and hardeners can result in irritation, dermatitis, and absorption of toxic, or harmful chemicals through the skin. Splashes can damage the eyes.

Provide adequate ventilation; avoid skin and eye contact. Follow manufacturer’s instructions.

Anaerobic Cyanoacrylate and other Acrylic Adhesives

Many are irritating, sensitizing, or harmful to the skin. Some are eye irritants.

Skin and eye contact should be avoided and the manufacturer's instructions followed.

Cyanoacrylate adhesives (super-glues) must not contact the skin or eyes. If skin or eye tissue is bonded, cover with a clean moist pad and get medical attention. Do not attempt to pull tissue apart. Use in well-ventilated areas as vapours can cause irritation of the nose and eyes.

For two-part systems: See Resin-Based Adhesive/ Sealers

Isocyanate (Polyurethane) Adhesive/Sealers (See Resin-Based Adhesives)

Individuals suffering from asthma or respiratory allergies should not work with, or near, these materials as sensitivity reactions can occur.

Any spraying should preferably be carried out in exhaust ventilated booths removing vapours and spray droplets from the breathing zone. Individuals working with spray applications should wear supplied air respirators.

ANTIFREEZE (SEE FIRE, SOLVENTS, I.E., ISOPROPANOL, ETHYLENE GLYCOL, METHANOL)

—————  **CAUTION**  —————

Highly flammable, combustible.

Used in vehicle coolant systems, brake air pressure systems, and windshield washing solutions.

Vapours given off from coolant antifreeze (Glycol) arise only when heated.

Antifreeze may be absorbed through the skin in toxic or harmful quantities. Swallowed antifreeze is fatal if not treated; medical attention must be sought immediately.

BATTERY ACIDS (SEE ACIDS AND ALKALIS)

Gases released during charging are explosive. Never use an open flame or allow sparks near charging or recently charged batteries.

(North America Only)

CALIFORNIA
Proposition 65 Warning
Battery posts, terminals and related accessories contain lead and lead compounds, chemicals known to the State of California to cause cancer and birth defects or other reproductive harm.
Wash hands after handling.

BRAKE AND CLUTCH LININGS AND PADS (SEE LEGAL ASPECTS)

These items may contain asbestos which, if inhaled, may cause lung damage and, in some cases, cancer.

The normal handling and fitting of these items should not cause any hazard, but any drilling, grinding, or filling of friction materials may produce asbestos dust and should only be carried out under strictly controlled conditions.

The dust in brake drums, etc., contains very little asbestos, but care should be taken to avoid inhalation of this dust during servicing of brakes and clutches. The use of drum cleaning units, vacuum cleaning, or damp wiping is preferred to the use of air jets for "blowing-out."

The dust should be collected in a sealed plastic bag and disposed appropriately, according to local laws and regulations.

BRAZING (SEE WELDING)

CHEMICAL MATERIALS - GENERAL (SEE LEGAL ASPECTS)

Chemical materials such as solvents, sealers, adhesives, paints, resin foams, battery acids, antifreeze, oils, and grease should always be used with caution, stored and handled with care. They may be toxic, harmful, corrosive, irritating, or highly flammable, causing hazardous fumes and dusts.

The effects of excessive exposure to chemicals may be immediate or delayed, briefly experienced or permanent, cumulative, superficial, life threatening, or may reduce life expectancy.

CLUTCH LININGS AND PADS (SEE BRAKE AND CLUTCH LININGS AND PADS)

CORROSION PROTECTION MATERIALS (SEE SOLVENTS, FIRE)



Highly flammable, combustible.

These materials are varied; the manufacturer's instructions should be followed. They may contain solvents, resins, and petroleum products. Skin and eye contact should be avoided. They should only be sprayed in conditions of adequate ventilation, and not in confined spaces.

CUTTING (SEE WELDING)

DEWAXING (SEE SOLVENTS AND FUELS - KEROSENE)

DO'S

Do remove chemical materials from the skin and clothing as soon as practicable. Change heavily soiled clothing and have it cleaned.

Do carefully read and observe hazard and precaution warnings given on material containers (labels) and in any accompanying leaflets, poster or other instructions. Material health and safety data sheets can be obtained from manufacturers.

Do organize work practices by wearing protective clothing and safety devices to avoid contact with chemical materials; breathing vapours, aerosols, dusts, and fumes; inadequate container labelling; or fire and explosion hazards.

Do wash before job breaks, before eating, smoking, drinking, or using toilet facilities when handling chemical materials.

Do keep work areas clean, uncluttered, and free of spills.

Do store according to national and local regulations.

Do keep chemical materials out of reach of children.

DON'TS

Do not mix chemical materials except under the manufacturer's instructions; some chemicals can form other toxic or harmful chemicals, releasing toxic or harmful fumes, or be explosive when mixed together.

Do not spray chemical materials, particularly those based on solvents, in confined spaces, i.e., when people are inside a vehicle.

Do not apply heat or flame to chemical materials, except under the manufacturer's instructions. Some are highly flammable, and some may release toxic or harmful fumes.

Do not leave containers open. Escaping fumes can build up to toxic, harmful, or explosive concentrations. Some fumes are heavier than air and will accumulate in confined areas, pits, etc.

Do not transfer chemical materials to unlabeled containers.

Do not clean hands or clothing with chemical materials. Chemicals, particularly solvents and fuels, will dry the skin, and may cause irritation with dermatitis. Some can be absorbed through the skin in toxic or harmful quantities.

Do not use emptied containers for other materials, except when they have been cleaned under supervised conditions.

Do not sniff or smell chemical materials. Brief exposure to high concentrations of fumes can be harmful or toxic.

DUSTS

Powder or dusts may be an irritant, harmful or toxic. Avoid breathing dusts from powdery chemical materials, or those arising from dry abrasion operations. Wear respiratory protection if ventilation is inadequate.

ELECTRIC SHOCK

Electric shocks can result from the use of faulty electrical equipment or from the misuse of equipment even in good condition.

Ensure electrical equipment is maintained in good condition and frequently tested.

Ensure flexes, cables, plugs and sockets are not frayed, kinked, cut, cracked, or otherwise damaged.

Ensure electric equipment is protected by the correct rated fuse.

Never use electrical equipment or any other equipment which is in any way faulty. The results could be fatal.

Use reduced voltage equipment for inspection and working lights, where possible.

Ensure the cables of mobile electrical equipment cannot get trapped and damaged, such as in a vehicle hoist.

In Cases of Electrocution:

- Switch off electricity before approaching victim.
- If this is not possible, push or drag the victim from the source of electricity using dry non-conductive material.
- Commence resuscitation if trained to do so.
- **SUMMON MEDICAL ASSISTANCE IMMEDIATELY.**

EXHAUST FUMES

These contain asphyxiating, harmful and toxic chemicals, and particles such as carbon oxides, nitrogen oxides, aldehydes, lead, and aromatic hydrocarbons. Engines should only run under conditions of adequate extraction, or general ventilation, not in confined spaces.

(North America Only)

<p style="text-align: center;">CALIFORNIA Proposition 65 Warning Diesel engine exhaust and some of its constituents are known to the State of California to cause cancer, birth defects and other reproductive harm.</p>

Diesel Engine

Soot, discomfort, and irritation usually give adequate warning signs of hazardous fume concentration.

FIBRE INSULATION (SEE DUSTS)

Used in noise and sound insulation.

The fibrous nature of surfaces and cut edge can cause skin irritation. This is usually a physical, not a chemical effect.

Precautions should be taken to avoid excessive skin contact through careful organization of work practices and the use of gloves.

FIRE (SEE WELDING, FOAMS, LEGAL ASPECTS)

Many of the materials found on, or associated with, the repair of vehicles are highly flammable. Some release toxic or harmful fumes if burned.

Observe strict fire safety when storing and handling flammable materials or solvents, particularly near electrical equipment or welding processes.

Before using electrical or welding equipment, be sure there is no fire hazard present.

Have a suitable fire extinguisher available when using welding or heating equipment.

FIRST AID

Apart from meeting any legal requirements, it is desirable for someone in the workshop to be trained in first aid procedures.

Splashes in the eye should be flushed with clean water for at least ten minutes.

Soiled skin should be washed with soap and water.

Inhalation affected individuals should be removed to fresh air immediately.

If chemicals are swallowed, consult a doctor immediately with (label) information on material used.

Do not induce vomiting, unless indicated by manufacturer.

FOAMS- POLYURETHANE (SEE FIRE)

Used in sound and noise insulation. Cured foams are used in seat and trim cushioning.

Follow manufacturer's instructions.

Unreacted components are irritating and may be harmful to the skin and eyes. Wear gloves and goggles.

Individuals with chronic respiratory diseases, asthma, bronchial medical problems, or histories of allergic diseases should not work with or near uncured materials.

The component's vapours and spray mists can cause direct irritation and/or sensitivity reactions and may be toxic or harmful.

Vapours and spray mists must not be breathed. These materials must be applied with adequate ventilation and respiratory protection. Do not remove respirator immediately after spraying, wait until vapour/mists have cleared.

Burning of the uncured components and the cured foams can generate toxic and harmful fumes.

Smoking, open flames, or the use of electrical equipment should not be allowed during foaming operations until vapours/mists have completely cleared. Any heat cutting of cured foams or partially cured foams should be conducted with extraction ventilation (see Legal Aspects).

FUELS (SEE FIRE, LEGAL ASPECTS, CHEMICALS - GENERAL, SOLVENTS)

Used as fuels and cleaning agents.

Gasoline (Petrol)

—————  **CAUTION**  —————

Highly flammable, combustible.

Swallowing can result in mouth and throat irritation; absorption from the stomach can result in drowsiness and unconsciousness. Small amounts can be fatal to children. Aspiration of liquid into the lungs, i.e., through vomiting, is a very serious hazard.

Prolonged or repeated contact with gasoline dries the skin and causes irritation and/or dermatitis. Liquid in the eye causes severe pain.

Motor gasoline may contain high quantities of benzene which is toxic upon inhalation; the concentrations of gasoline vapours must be kept very low. High concentrations will cause eye, nose and throat irritation, nausea, headache, depression and symptoms of drunkenness. Very high concentrations will result in rapid loss of consciousness.

Ensure there is adequate ventilation when handling and using gasoline. Great care must be taken to avoid the serious consequences of inhalation in the event of vapour build-up arising from spillages in confined spaces.

Special precautions apply to cleaning and maintenance operations on gasoline storage tanks.

Gasoline should not be used as a cleaning agent. It must not be siphoned by mouth.

Kerosene (Paraffin)

Used also as heating fuel, solvent, and cleaning agent.

—————  **CAUTION**  —————

Flammable.

Irritation of the mouth and throat may result from swallowing. The main hazard from swallowing arises if liquid aspiration into the lungs occurs. Liquid contact dries the skin and can cause irritation and/or dermatitis. Splashes in the eye may be slightly irritating.

In normal circumstances, the low volatility does not give rise to harmful vapours. Exposure to mists and vapours from kerosene at elevated temperatures should be avoided (mists may arise in dewaxing). Avoid skin and eye contact; be sure there is adequate ventilation.

Diesel Fuel (Gas-Oil) (See Fuels-Kerosene)

—————  **CAUTION**  —————

Combustible.

Gross or prolonged skin contact with high boiling gas oils may cause serious skin disorders, including skin cancer.

GAS CYLINDERS (SEE FIRE)

Gases such as oxygen, acetylene, carbon dioxide, argon, and propane are normally stored in cylinders at pressures of up to 2000 PSI (137.8 bar). Great care should be taken in handling these cylinders to avoid mechanical damage to them or the valve gear attached. The contents of each cylinder should be clearly identified by appropriate markings.

Cylinders should be stored in well-ventilated enclosures and protected from ice, snow, or direct sunlight. Fuel gases, i.e., acetylene and propane, should not be stored in close proximity to oxygen cylinders.

Care should be exercised to prevent leaks from gas cylinders and lines and to avoid sources of ignition.

Only trained personnel should undertake work involving gas cylinders.

GASES (SEE GAS CYLINDER)

GAS SHIELDING WELDING (SEE WELDING)

GAS WELDING (SEE WELDING)

GENERAL WORKSHOP TOOLS AND EQUIPMENT

It is essential that all tools and equipment are maintained in good condition and the correct safety equipment used where required.

Never use tools or equipment for any purpose other than for which they were designed.

Never overload equipment such as hoists, jacks, axle and chassis Stands, or lifting slings. Damage caused by overloading is not always immediately apparent and may result in a fatal failure the next time the equipment is used.

Do not use damaged, defective tools or equipment, particularly high-speed equipment such as grinding wheels. A damaged grinding wheel can disintegrate without warning causing serious injury.

Wear suitable eye protection when using grinding, chiselling, or sandblasting equipment.

Wear a suitable breathing mask when using sandblasting equipment, working with asbestos based materials, or using spraying equipment.

GLUES (SEE ADHESIVE AND SEALERS)

HIGH-PRESSURE AIR, LUBRICATION AND OIL TEST EQUIPMENT (SEE LUBRICANTS AND GREASES)

Always keep high-pressure equipment in good condition and regularly maintained, particularly joint and unions.

Never direct a high-pressure nozzle at the skin, as the fluid may penetrate to the underlying tissue and can cause serious injury.

LEGAL ASPECTS

Many laws and regulations make requirements relating to health and safety in the use of materials and equipment in workshops.

Workshops should be familiar, in detail, with these laws and regulations.

LUBRICANTS AND GREASES

Avoid all prolonged and repeated contact with mineral oils, especially used oils. Gross and prolonged skin contact with used oils contaminated during service, i.e., routine service change sump oils, are more irritating and more likely to cause serious effects, including skin cancer.

Wash skin thoroughly after work involving oil. Proprietary hand cleaners may be of value provided they can be removed from the skin with water. Do not use petrol, paraffin, or other solvents to remove oil from the skin.

Lubricants and greases may be slightly irritating to the eyes.

Repeated or prolonged skin contact should be avoided by wearing protective clothing, if necessary. Particular care should be taken with used oils and greases containing lead. Do not allow work clothing to be contaminated with oil. Dry clean or launder such clothing at regular intervals. Discard oil-soaked shoes.

Do not use previously used engine oils as lubricants or for any application where major skin contact is likely to occur. Used oils may only be disposed of in accordance with local regulations.

Refer to the "Recommended Lubricants and Coolants Charts", for the recommended lubricants.

NOISE INSULATION MATERIAL (SEE FOAMS, FIBRE INSULATION)

PAINTS (SEE SOLVENTS AND CHEMICAL MATERIALS- GENERAL)

—————  **CAUTION**  —————

Highly flammable.

Paints can contain harmful or toxic pigments, driers, and other components, as well as solvents. Spraying should only be carried out with adequate ventilation.

Two-part or catalysed paints can also contain harmful and toxic unreacted resins and resin-hardening agents. The manufacturer's instructions should be followed and the section on resin-based adhesives, isocyanate containing adhesive and foams should be consulted.

Spraying should preferably be carried out in exhausted ventilated booths, removing vapour and spray mists from the breathing zone. Individuals working in booths should wear respiratory protection. Those doing small-scale repair work in the open shop should wear supplied air respirators.

PAINT THINNERS (SEE SOLVENTS)

PRESSURIZED EQUIPMENT (SEE HIGH-PRESSURE AIR, LUBRICATION AND OIL TEST EQUIPMENT)

RESISTANCE WELDING (SEE WELDING)

SEALERS (SEE ADHESIVES AND SEALERS)

SOLDER (SEE WELDING)

Solders are mixtures of metals in which the melting point of the mixture is below that of constituent metals (normally lead and tin). Solder application does not normally give rise to toxic lead fumes, provided a gas/air flame is used. Oxyacetylene flames should not be used, as they are much hotter and will cause lead fumes to be released.

Some fumes may be produced by the application of anyflame to surfaces coated with grease, etc., and inhalation of these should be avoided.

IDENTIFICATION NUMBERS

TRACTOR IDENTIFICATION DATA

The tractor and its major components are identified using serial numbers and/or manufacturing codes.

NOTE: The tractor identification data must be supplied to the dealer when requesting parts or service. Identification data is also needed to aid in identifying the tractor if it is ever stolen.

VEHICLE IDENTIFICATION PLATE

The vehicle identification plate (1) is located on the lower left front corner of the cab.

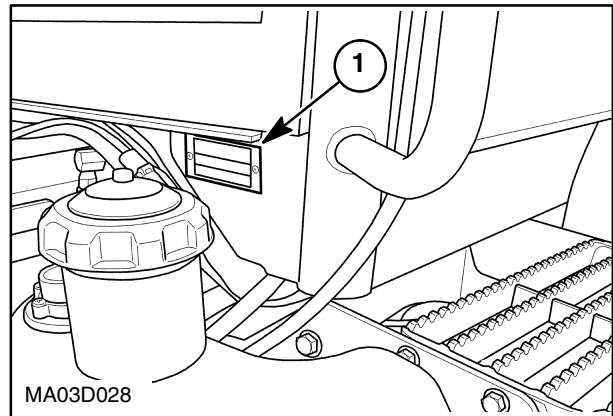

1

Record the Model Number and Product Identification Number, for future quick reference.

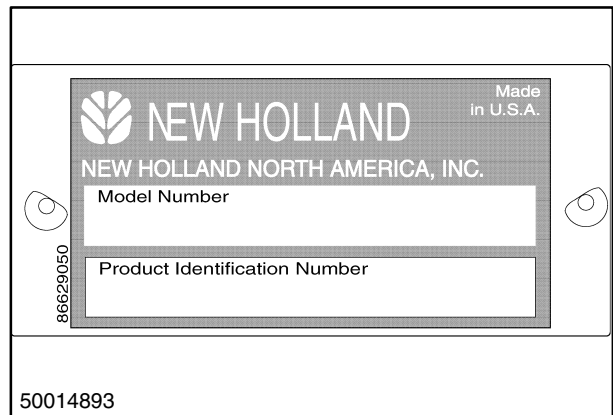

2

ENGINE IDENTIFICATION

The engine serial number is stamped on a flat boss area on the right side of the engine block below the starter and to the rear of the block, just above the oil pan (1).

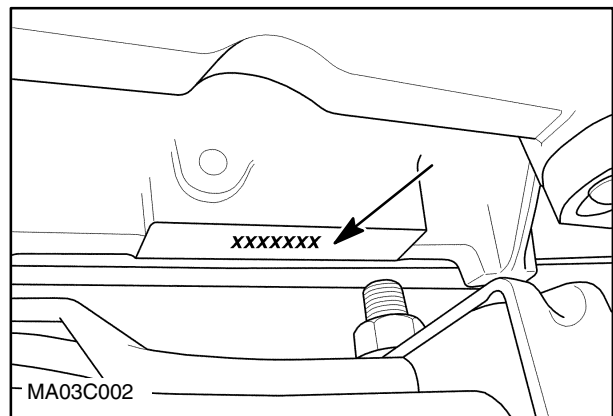

3

SECTION 00 – GENERAL INFORMATION

ENGINE IDENTIFICATION

The engine identification information is located on a tag (1) on the right side of the engine rocker cover.

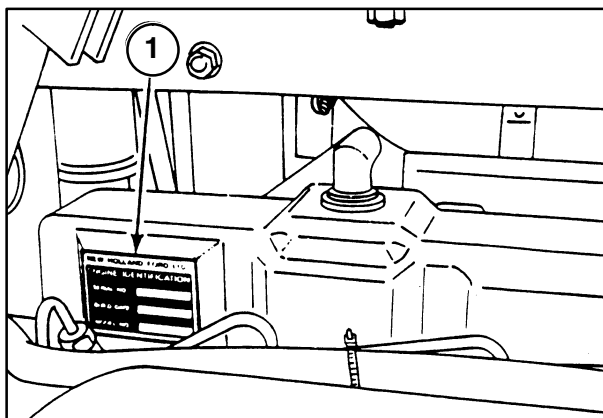

4

FUEL INJECTION PUMP IDENTIFICATION

The serial number and pump information are on the plate (1) on the pump.

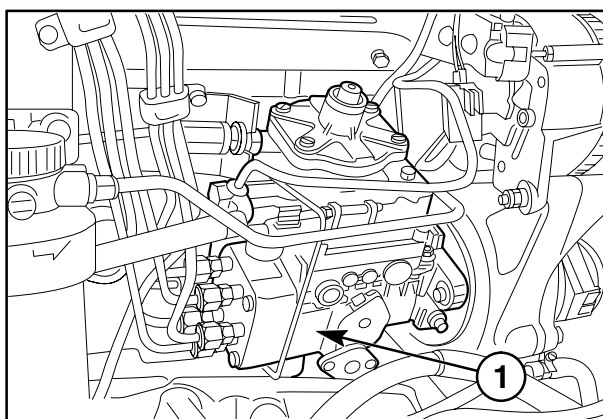

5

The following is a key to the identification plate:

- 011 = Factory code (Germany)
 - 36202 01323 15194 = Serial number
 - 0400876405 = Supplier order number
 - PES6A95D410RS2835 = Alphanumeric production designation
- PE = Inline injection pump with camshaft
S = Flange-mounted
6 = Number of cylinders
A = Size pump (A - 8670 and 8770,
P - 8870 and 8970)
95 = Plunger diameter in 1/10 mm (915 mm)
D = Pump model ("D" is the latest version of "A"
size pumps)
410 = Number code for location of feed pump and
governor
R = Rotation of pump as seen from drive end
(right hand = clockwise)
S2835 = Application number (indicates what
model New Holland tractor this is used on)



6

SECTION 00 – GENERAL INFORMATION

STARTER MOTOR IDENTIFICATION

The serial number and starter information are on the plate (1) on the starter housing.

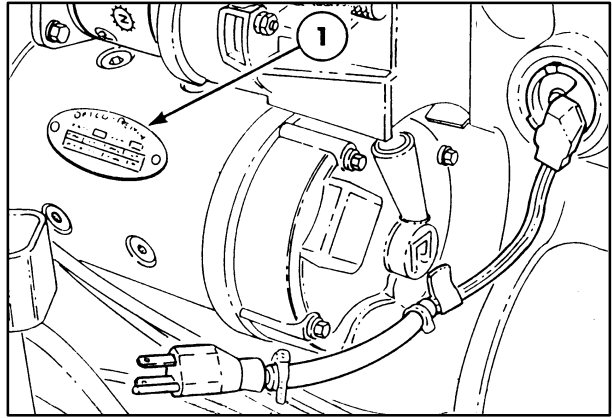

7

REAR AXLE IDENTIFICATION

The serial number (1) is stamped on the left side of the PTO boss on the rear axle housing.

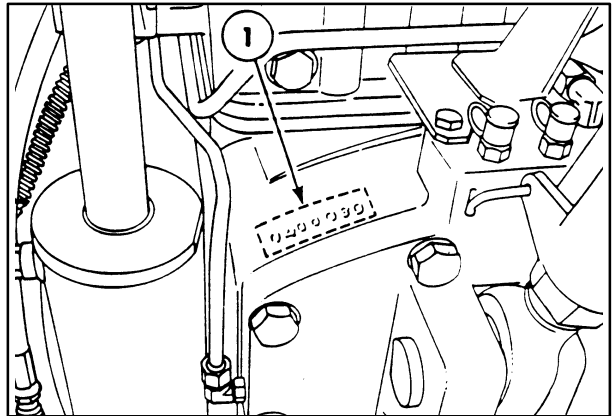

8

CAB IDENTIFICATION

The serial number is on the certification plate (1) on the rear crossbar.

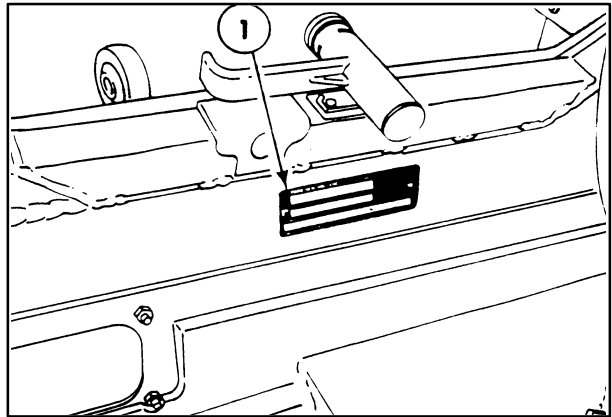

9

SERVICE TECHNIQUES

GENERAL

Clean the exterior of all components before carrying out any form of repair. Dirt and abrasive dust can reduce the efficient working life of a component and lead to costly replacement.

Time spent on the preparation and cleanliness of working surfaces will pay dividends in making the job easier and safer and will result in overhauled components being more reliable and efficient in operation.

Use cleaning fluids which are known to be safe. Certain types of fluid can cause damage to O rings and cause skin irritation. Solvents should be checked that they are suitable for the cleaning of components and also that they do not risk the personal safety of the user.

Replace O rings, seals or gaskets whenever they are disturbed. Never mix new and old seals or O rings, regardless of condition. Always lubricate new seals and O rings with hydraulic oil before installation.

When replacing component parts, use the correct tool for the job.

HOSES AND TUBES

Always replace hoses and tubes if the cone end or the end connections on the hose are damaged.

When installing a new hose, loosely connect each end and make sure the hose takes up the designed

position before tightening the connection. Clamps should be tightened sufficiently to hold the hose without crushing and to prevent chafing.

After hose replacement to a moving component, check that the hose does not foul by moving the component through the complete range of travel.

Be sure any hose which has been installed is not kinked or twisted.

Hose connections which are damaged, dented, crushed or leaking, restrict oil flow and the productivity of the components being served. Connectors which show signs of movement from the original swagged position have failed and will ultimately separate completely.

A hose with a chafed outer cover will allow water entry. Concealed corrosion of the wire reinforcement will subsequently occur along the hose length with resultant hose failure.

Ballooning of the hose indicates an internal leakage due to structural failure. This condition rapidly deteriorates and total hose failure soon occurs.

Kinked, crushed, stretched or deformed hoses generally suffer internal structural damage which can result in oil restriction, a reduction in the speed of operation and ultimate hose failure.

Free-moving, unsupported hoses must never be allowed to touch each other or related working surfaces. This causes chafing which reduces hose life.

MINIMUM HARDWARE TIGHTENING TORQUES

IN FOOT POUNDS (NEWTON-METERS) FOR NORMAL ASSEMBLY APPLICATIONS

INCH HARDWARE AND LOCKNUTS

NOMINAL SIZE	SAE GRADE 2		SAE GRADE 5		SAE GRADE 8		LOCKNUTS		NOMINAL SIZE
	UNPLATED or PLATED SILVER	PLATED W/ZnCr GOLD	UNPLATED or PLATED SILVER	PLATED W/ZnCr GOLD	UNPLATED or PLATED SILVER	PLATED W/ZnCr GOLD	GR.B w/GR5 BOLT	GR.C w/GR8 BOLT	
1/4	55* (6.2)	72* (8.1)	86* (9.7)	112* (13)	121* (14)	157* (18)	61* (6.9)	86* (9.8)	1/4
5/16	115* (13)	149* (17)	178* (20)	229* (26)	250* (28)	324* (37)	125* (14)	176* (20)	5/16
3/8	17 (23)	22 (30)	26 (35)	34 (46)	37 (50)	48 (65)	19 (26)	26 (35)	3/8
7/16	27 (37)	35 (47)	42 (57)	54 (73)	59 (80)	77 (104)	30 (41)	42 (57)	7/16
1/2	42 (57)	54 (73)	64 (87)	83 (113)	91 (123)	117 (159)	45 (61)	64 (88)	1/2
9/16	60 (81)	77 (104)	92 (125)	120 (163)	130 (176)	169 (229)	65 (88)	92 (125)	9/16
5/8	83 (112)	107 (145)	128 (174)	165 (224)	180 (244)	233 (316)	90 (122)	127 (172)	5/8
3/4	146 (198)	189 (256)	226 (306)	293 (397)	319 (432)	413 (560)	160 (217)	226 (306)	3/4
7/8	142 (193)	183 (248)	365 (495)	473 (641)	515 (698)	667 (904)	258 (350)	364 (494)	7/8
1	213 (289)	275 (373)	547 (742)	708 (960)	773 (1048)	1000 (1356)	386 (523)	545 (739)	1

NOTE: Torque values shown with * are inch pounds.

IDENTIFICATION CAP SCREWS AND CARRIAGE BOLTS



LOCKNUTS

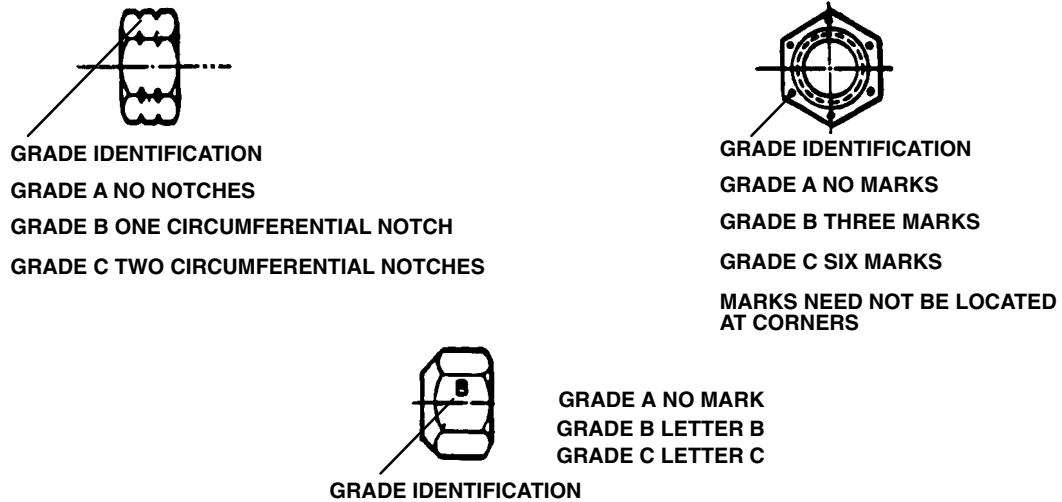

MINIMUM HARDWARE TIGHTENING TORQUES

IN FOOT POUNDS (NEWTON-METERS) FOR NORMAL ASSEMBLY APPLICATIONS

METRIC HARDWARE AND LOCKNUTS

NOMINAL SIZE	CLASS 5.8		CLASS 8.8		CLASS 10.9		LOCKNUT CL.8 W/CL.8.8 BOLT
	UNPLATED	PLATED W/ZnCr	UNPLATED	PLATED W/ZnCr	UNPLATED	PLATED W/ZnCr	
M4	15* (1.7)	19* (2.2)	23* (2.6)	30* (3.4)	33* (3.7)	42* (4.8)	16* (1.8)
M6	51* (5.8)	67* (7.6)	79* (8.9)	102* (12)	115* (13)	150* (17)	56* (6.3)
M8	124* (14)	159* (18)	195* (22)	248* (28)	274* (31)	354* (40)	133* (15)
M10	21 (28)	27 (36)	32 (43)	41 (56)	45 (61)	58 (79)	22 (30)
M12	36 (49)	46 (63)	55 (75)	72 (97)	79 (107)	102 (138)	39 (53)
M16	89 (121)	117 (158)	137 (186)	177 (240)	196 (266)	254 (344)	97 (131)
M20	175 (237)	226 (307)	277 (375)	358 (485)	383 (519)	495 (671)	195 (265)
M24	303 (411)	392 (531)	478 (648)	619 (839)	662 (897)	855 (1160)	338 (458)

NOTE: Torque values shown with * are inch pounds.

IDENTIFICATION HEX CAP SCREW AND CARRIAGE BOLTS CLASSES 5.6 AND UP

MANUFACTURER'S IDENTIFICATION

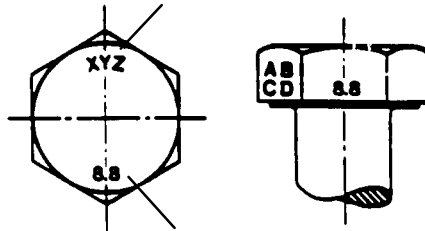

PROPERTY CLASS

HEX NUTS AND LOCKNUTS CLASSES 05 AND UP

MANUFACTURER'S IDENTIFICATION

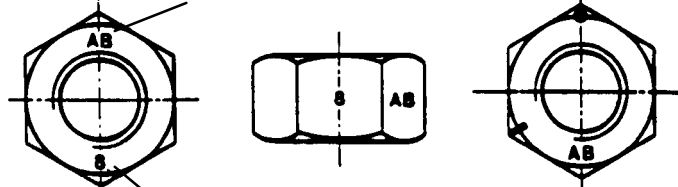

PROPERTY CLASS

CLOCK MARKING

**Thanks very much for your reading,
Want to get more information,
Please click here, Then get the complete
manual**

JustClickHere 

NOTE:

**If there is no response to click on the link above,
please download the PDF document first, and then
click on it.**

**Have any questions please write to me:
admin@servicemanualperfect.com**